

THIS DOCUMENT IS THE PROPERTY OF SELECT CONTROLS INCORPORATED AND IS CONVEYED WITH THE EXPRESS CONDITION THAT IT AND THE INFORMATION CONTAINED IN IT ARE NOT TO BE USED, DISCLOSED, OR REPRODUCED IN WHOLE OR IN PART, FOR ANY PURPOSE WITHOUT THE EXPRESS WRITTEN CONSENT OF SELECT CONTROLS INCORPORATED; AND THAT NO RIGHT IS GRANTED TO DISCLOSE OR SO USE ANY INFORMATION CONTAINED IN SAID DOCUMENT.

4008-2-000

REVISIONS				
ALT	DESCRIPTION	BY	CHK	ENG

NOTE:

1. SWITCH: PLANAR, NORMALLY OPEN, AUTOMATICALLY RESETTABLE
2. WEIGHT: 2 GRAMS MAXIMUM
3. CONTACTS: SPST, NORMALLY OPEN
4. CONTACT RESISTANCE: 500 OHMS MAXIMUM
5. CONTACT RATING: 150MA AT 28VDC
6. INSULATION RESISTANCE: 30 MEGOHMS MINIMUM AT 500VDC
7. OPERATING CHARACTERISTICS:
 - a) MUST CLOSE WHEN TILTED PAST 75° FROM VERTICAL POSITION
 - a) MUST OPEN WHEN RETURNED TO VERTICAL POSITION
8. TEMPERATURE RANGE:
 - a) OPERATING: -65°F TO +185°F
 - b) NON-OPERATING: -65°F TO +221°F
9. SWITCH SEAL: HERMETIC; LEAKAGE SHALL NOT EXCEED 1×10^{-6} SCCS He AT 1 ATM.
10. LEAD STRENGTH: 3 LBS. MINIMUM AXIAL PULL.

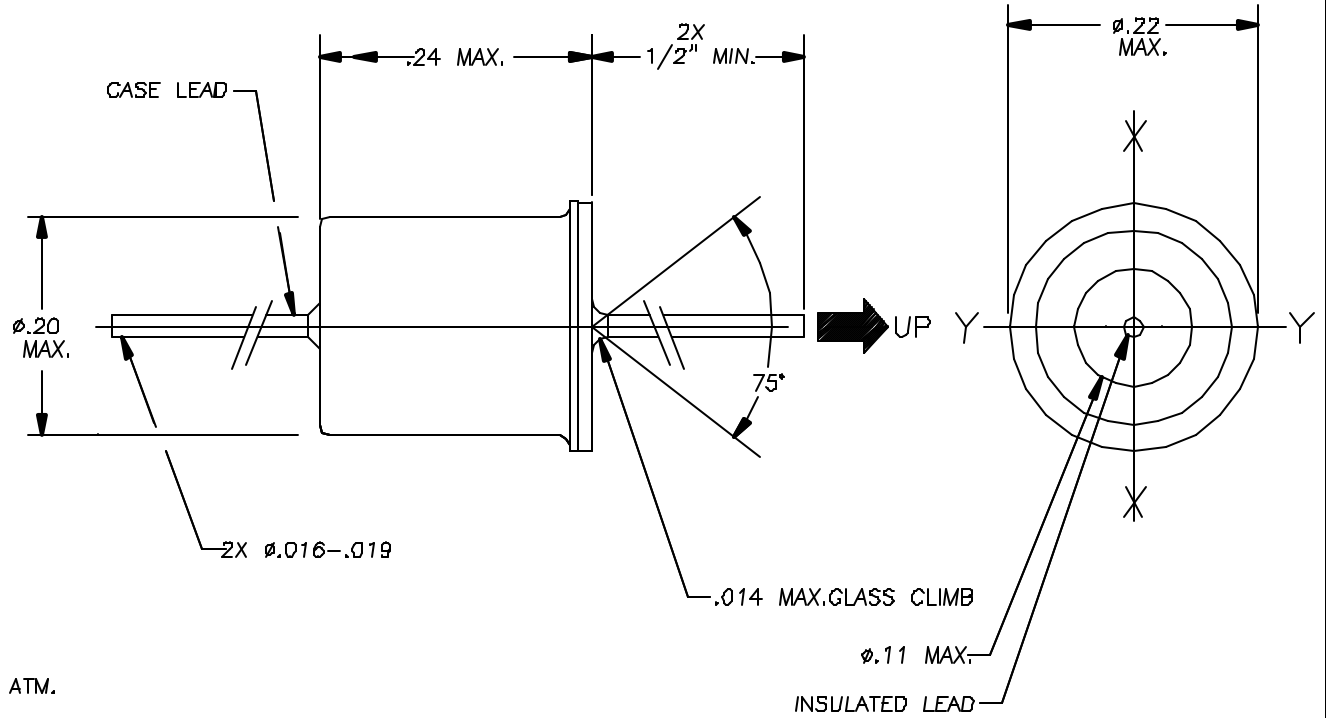

MATERIAL	_____
FINISH	_____

ITEM	NO. REQ'D	PART NO.	DESCRIPTION	REMARKS
BILL OF MATERIAL				
TITLE SWITCH, MOTION/DISTURBANCE N.O., AXIAL LEADS			 45-3 KNICKERBOCKER AVE. BOHEMIA, N.Y. 11716	
DO NOT SCALE DRAWING REMOVE BURRS, BREAK SHARP EDGES TOLERANCES UNLESS SPECIFIED: FRACT: ±1/64 ANGLE: ±0.20° MACH FINISH: 125/ RFB DEC: 60 ±.010 DEC: 600 ±.005		NO. REQ'D N/A	NO. REQ'D N/A	SCALE: 10:1 WEIGHT: NOTED
DESIGN	CHKD	DATE	DRAWING NO.	REV
		3/10/07	4008-2-000	
			SHEET 1 OF 1	