

THIS DOCUMENT IS THE PROPERTY OF SELECT CONTROLS INCORPORATED AND IS CONVEYED WITH THE EXPRESS CONDITION THAT IT AND THE INFORMATION CONTAINED IN IT ARE NOT TO BE USED, DISCLOSED, OR REPRODUCED IN WHOLE OR IN PART, FOR ANY PURPOSE WITHOUT THE EXPRESS WRITTEN CONSENT OF SELECT CONTROLS INCORPORATED; AND THAT NO RIGHT IS GRANTED TO DISCLOSE OR SO USE ANY INFORMATION CONTAINED IN SAID DOCUMENT.

NOTE:

1. SWITCH: PLANAR, NORMALLY OPEN, AUTOMATICALLY RESETTABLE
2. WEIGHT: 2 GRAMS MAXIMUM
3. CONTACTS: SPST, NORMALLY OPEN
4. CONTACT RESISTANCE: 500 OHMS MAXIMUM
5. CONTACT RATING: 150MA AT 28VDC
6. INSULATION RESISTANCE: 30 MEGOHMS MINIMUM AT 500VDC
7. OPERATING CHARACTERISTICS:
 - a) MUST CLOSE—
WHEN TILTED PAST 90° FROM VERTICAL POSITION
—OR—
WHEN SUBJECTED TO DISTURBANCES (MOTION) IN THE X-Y PLANE
 - b) MUST OPEN—
WHEN RETURNED TO VERTICAL POSITION
—OR—
RETURNED TO AT REST POSITION
8. TEMPERATURE RANGE:
 - a) OPERATING: -65°F TO +185°F
 - b) NON-OPERATING: -65°F TO +221°F
9. SWITCH SEAL: HERMETIC; LEAKAGE SHALL NOT EXCEED 1×10^{-6} SCCS He AT 1 ATM.
10. LEAD STRENGTH: 3 LBS. MINIMUM AXIAL PULL.

4007-1-000

| REVISIONS | | | | |
|-----------|-------------|----|-----|-----|
| ALT | DESCRIPTION | BY | CHK | ENG |
| | | | | |

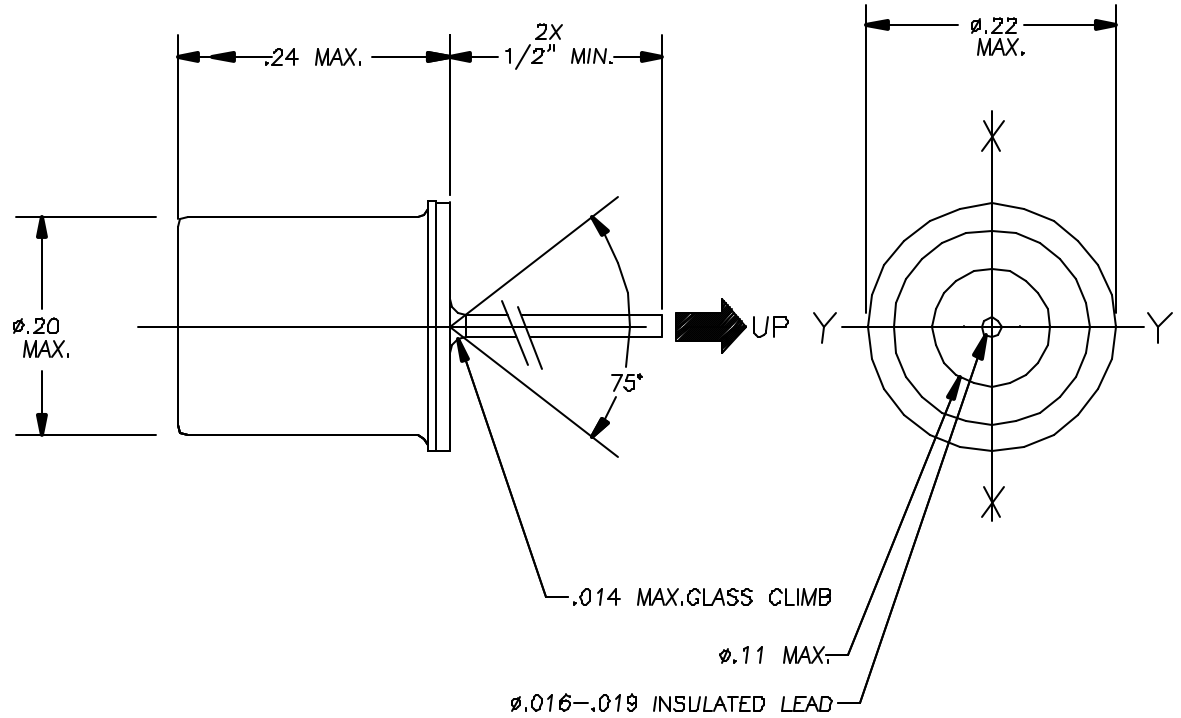

| | |
|----------|-------|
| MATERIAL | _____ |
| FINISH | _____ |

DO NOT SCALE DRAWING
REMOVE BURRS, BREAK SHARP EDGES
TOLERANCES UNLESS SPECIFIED:
FRACT: ±1/64 ANGLE ±0.30°
MACH FINISH 125/ RFB DEC: .00 ±.010 DEC: .000 ±.005

| ITEM | NO | PART NO. | DESCRIPTION | REMARKS |
|------------------|-----|-----------|--|---------------|
| BILL OF MATERIAL | | | | |
| TITLE | | |  45-3 KNICKERBOCKER AVE. BOHEMIA, N.Y. 11716 | |
| NO. REQ'D | N/A | NO. REQ'D | N/A | SCALE: 10:1 |
| WEIGHT: | | | NOTED | DATE: 3/21/07 |
| DRAWING NO. | | | 4007-1-000 | |
| SHEET | | | 1 OF 1 | |