

THIS DOCUMENT IS THE PROPERTY OF SELECT CONTROLS INCORPORATED AND IS CONVEYED WITH THE EXPRESS CONDITION THAT IT AND THE INFORMATION CONTAINED IN IT ARE NOT TO BE USED, DISCLOSED, OR REPRODUCED IN WHOLE OR IN PART, FOR ANY PURPOSE WITHOUT THE EXPRESS WRITTEN CONSENT OF SELECT CONTROLS INCORPORATED; AND THAT NO RIGHT IS GRANTED TO DISCLOSE OR SO USE ANY INFORMATION CONTAINED IN SAID DOCUMENT.

NOTE:

1. SWITCH: UNIDIRECTIONAL, NORMALLY OPEN, AUTOMATICALLY RESETTABLE
2. WEIGHT: 2 GRAMS MAXIMUM
3. CONTACTS: SPST, NORMALLY OPEN
4. CONTACT RESISTANCE: 10 OHMS MAXIMUM
5. CONTACT RATING: 50MA AT FOR 2 MINUTES
6. INSULATION RESISTANCE: 30 MEGOHMS MINIMUM
7. OPERATING CHARACTERISTICS (SPIN THRESHOLD):
 - a) FOR INCREASING RPM, THE SWITCH SHALL REMAIN OPEN BELOW THE MINIMUM SWITCH CLOSURE RPM AND SHALL BE CLOSED AT AND ABOVE THE MAXIMUM SWITCH CLOSURE RPM PER TABLE I
 - b) FOR DECREASING RPM AFTER SWITCH CLOSURE, THE SWITCH SHALL OPEN WITHIN 25 PERCENT BELOW THE NOMINAL SWITCH CLOSURE RPM OF TABLE I
8. TEMPERATURE RANGE:
 - a) HIGH TEMPERATURE: +160°F TO +220°F
 - b) LOW TEMPERATURE: -65°F
 - c) STORAGE TEMPERATURE: -65°F TO +160°F
9. SHOCK TEST: HALF SINE SHOCK EVENT, 80 G PEAK ACCELERATION FOR 11MS DURATION, 6 SHOCKS POSITIVE AND 6 SHOCKS NEGATIVE
10. SWITCH SEAL: HERMETIC; PER MIL-STD-750C, METHOD 1071
11. LEAD STRENGTH: 5 LBS. MINIMUM AXIAL PULL

2044-SEE TABLE SAL-000

B

REVISIONS				
ALT	DESCRIPTION	BY	CHK	ENG
A	SEE ECN2044-SEE SAL-000A TABLE	AHN 10/24/02		
B	SEE ECN2044-SEE SAL-000B TABLE	AHN 2/3/00		

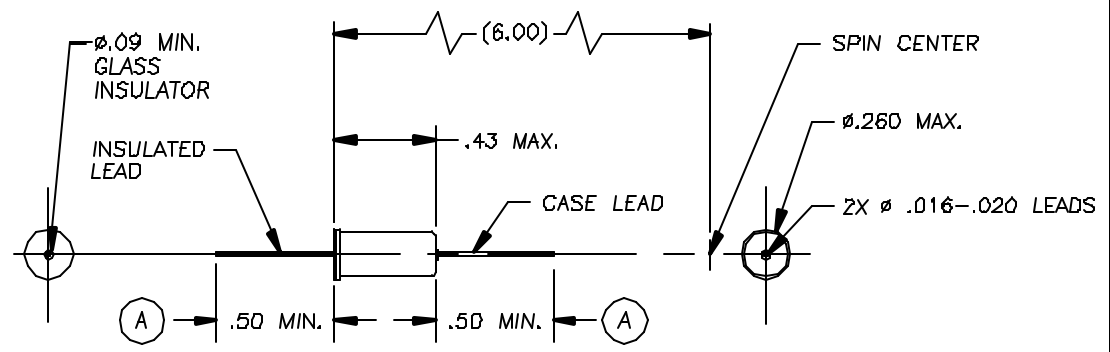

TABLE I

NOMINAL g'S	g LEVEL TOLERANCE	SELECT CONTROLS P/N	SWITCH CLOSURE RPM @ 6" SPIN RADIUS
44	+12%/-10%	2044-1SAL-000	475 500 560
163	+5%/-5%	2044-3SAL-000	950 1000 1050
368	+5%/-5%	2044-5SAL-000	1425 1500 1575
654	+5%/-5%	2044-7SAL-000	1900 2000 2100
1022	+5%/-5%	2044-11SAL-000	2375 2500 2625

ITEM	NO.	PART NO.	DESCRIPTION	REMARKS
BILL OF MATERIAL				

MATERIAL _____

FINISH _____

DO NOT SCALE DRAWING
REMOVE BURRS, BREAK SHARP EDGES
TOLERANCES UNLESS SPECIFIED:
FRACTIONS: ±1/64 ANGLE: ±0.30°
MACH FINISH: 125/ RBS DEC: .00 ±.010 DEC: .000 ±.005

TITLE SWITCH, SPIN

Scale: 2:1

WEIGHT: _____

DATE: _____

APPROVED: _____

DATE: _____

REVISIONS:

NO. REV'D	N/A	NO. REV'D	N/A	SCALE	2:1	DESIGN	AHN	DATE	5/28/02	DRAWING NO.	2044-SEE TABLE SAL-000	REV	B
-----------	-----	-----------	-----	-------	-----	--------	-----	------	---------	-------------	------------------------	-----	---

APPROVED: _____ DATE: _____ SHEET 1 OF 1

Select Controls Inc.
45-3 KNICKERBOCKER AVE.
BOHEMIA, N.Y. 11716